

Recent results from NA48 experiment

Andrea Michetti

on behalf of NA48 collaboration

`andrea.michetti@cern.ch`

Perugia University

Chiral Perturbation Theory tests

- χPT describes low energy processes where QCD is non-perturbative
- It is based on perturbative expansion of momenta and masses: $\frac{p^2}{(4\pi F_\pi)^2}, \frac{m^2}{(4\pi F_\pi)^2}$ where $(4\pi F_\pi) \sim 1.2 \text{ GeV}$
- Two experimental tests of the theory will be presented
 - $K_S \rightarrow \gamma\gamma$
 - $K_S \rightarrow \pi^0 \gamma\gamma$
- They all have $\mathcal{O}(p^2) = 0$ and $\mathcal{O}(p^4)$ precisely predicted

The beam

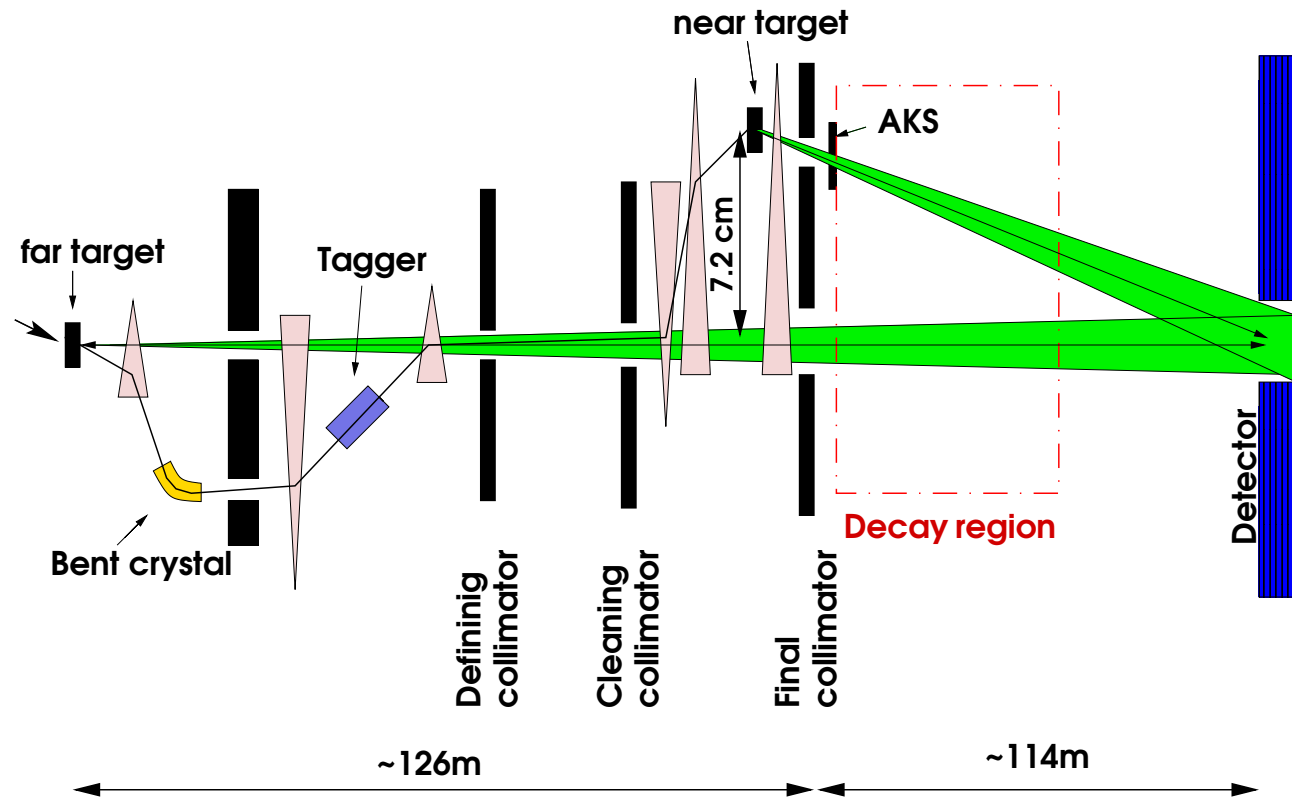

The detector

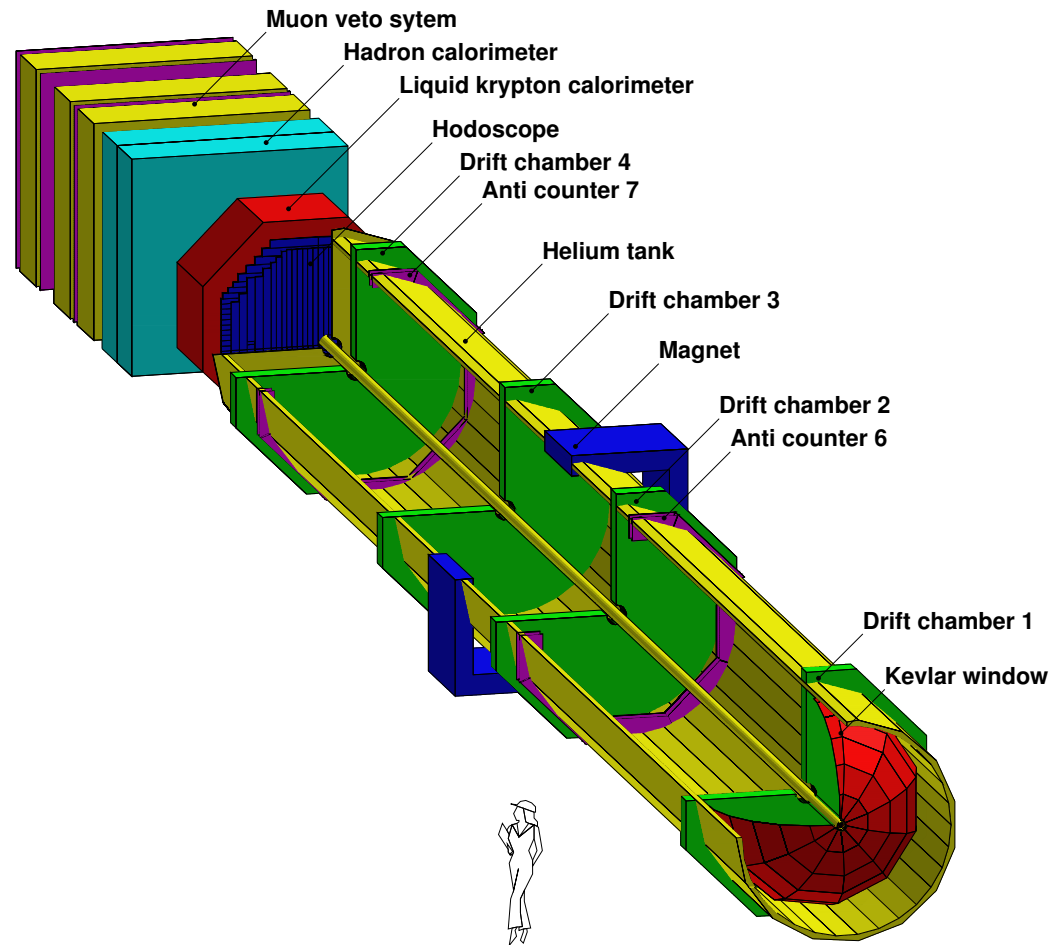

NA48 data taking periods

Year	Beam type	Physics program
1997	$K_L + K_S$	ϵ'/ϵ
1998	$K_L + K_S$	ϵ'/ϵ , K_S lifetime, $K_L \rightarrow \pi^0 \gamma \gamma$, ...
1999	$K_L + K_S$	ϵ'/ϵ , $K_L \rightarrow \pi^0 \gamma \gamma$, ...
2000 No spectrometer	K_L only η run K_S high intensity	K^0 mass, $K_L \rightarrow \gamma \gamma$, ϵ'/ϵ checks η mass $K_S \rightarrow \gamma \gamma$, ...
2001	$K_L + K_S$	ϵ'/ϵ
2002	K_S high intensity	Hyperon physics, K_S rare decays
2003	K^+, K^-	CP violation in charged Kaons

The z_{vertex} reconstruction

$$z_{vertex} = z_{LKR} - \frac{1}{m_{K_0}} \sqrt{\sum_{i,j < i} E_i E_j [(x_i - x_j)^2 + (y_i - y_j)^2]}$$

Requirements for Kaon decay vertex reconstruction

- Good cluster energy resolution
- Good impact point resolution

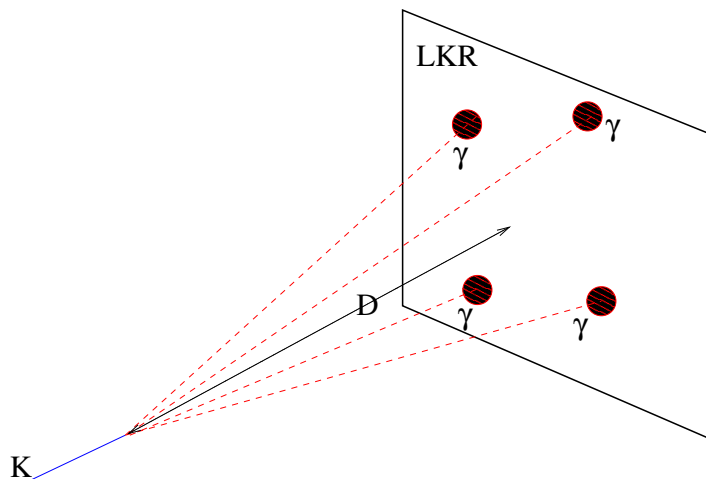

$$\frac{\sigma(E)}{E} = \frac{0.09}{E} \oplus \frac{0.032}{\sqrt{E}} \oplus 0.0042$$

$$\sigma_{x,y} = 1.3 \text{ mm}$$

$$\sigma_t = 300 \text{ ps}$$

$K_S \rightarrow \gamma\gamma$

- χPT at $\mathcal{O}(p^4)$ predicts BR = 2.1×10^{-6} (few % error)
(D'Ambrosio-Espriu, J.L. Goity)
- Data from 2000 near-target run.
- Main background sources
 - $K_S \rightarrow \pi^0\pi^0$ with two showers in LKR:
 - overestimation of z_{rec} (> 9 meters)
 - decay region $-1 \text{ m} < z_{vertex} < 5 \text{ m}$
 - $K_L \rightarrow \gamma\gamma$ irreducible ($\sim 1.5 K_S \rightarrow \gamma\gamma$)
 - $K_L \rightarrow 3\pi^0$ to estimate K_L flux
 - “far-target” data used to measure $\frac{\Gamma(K_L \rightarrow \gamma\gamma)}{\Gamma(K_L \rightarrow 3\pi^0)}$

Background subtraction

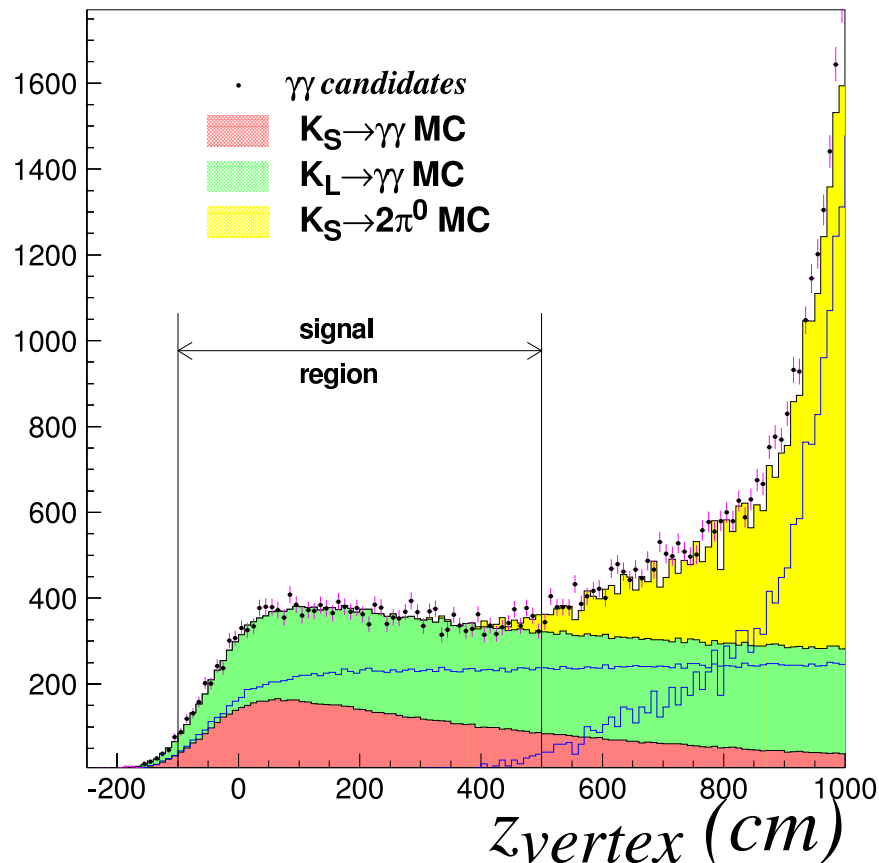

- Background from $\pi^0\pi^0$ subtracted using MC normalized to the fully reconstructed $\pi^0\pi^0$ events
- $K_L \rightarrow \gamma\gamma$ estimated from the “far-target” run because from PDG

$$\frac{\Gamma(K_L \rightarrow \gamma\gamma)}{\Gamma(K_L \rightarrow 3\pi^0)} = (2.77 \pm 0.08) \times 10^{-3}$$

Not enough precise !

$$\frac{\Gamma(K_L \rightarrow \gamma\gamma)}{\Gamma(K_L \rightarrow 3\pi^0)} = (2.81 \pm 0.01_{stat} \pm 0.02_{syst}) \times 10^{-3}$$

Experiment-theory comparison

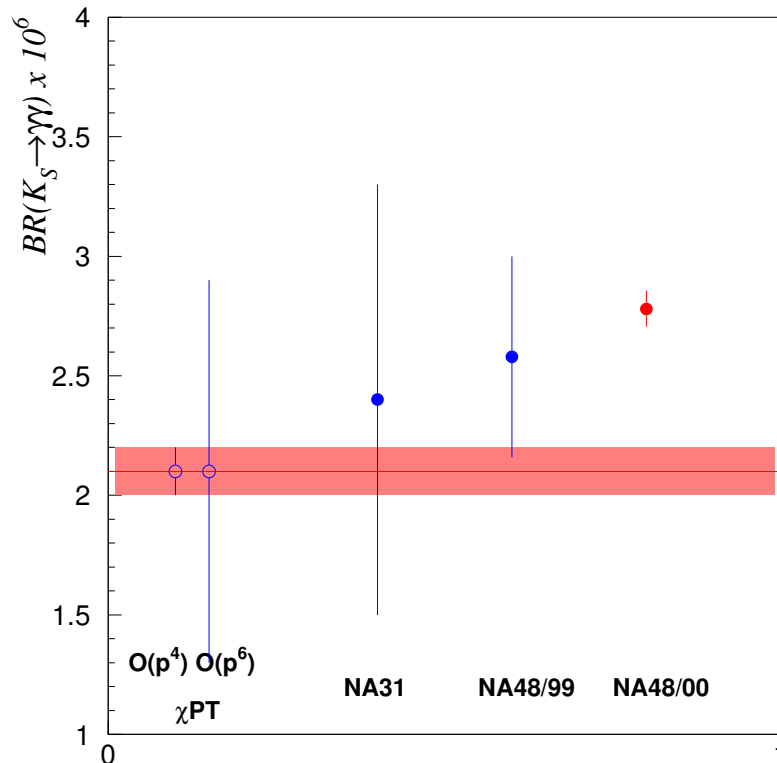

- Compatibility with previous measurements.
- NA48/00 differs by 30% from $\mathcal{O}(p^4)$ prediction of $\chi PT \implies$ Indication of a large $\mathcal{O}(p^6)$ contribution.

$$BR(K_S \rightarrow \gamma\gamma) = (2.78 \pm 0.06_{sys} \pm 0.03_{stat} \pm 0.02_{ext}) \times 10^{-6}$$

$K_S \rightarrow \pi^0 \gamma \gamma$: theory

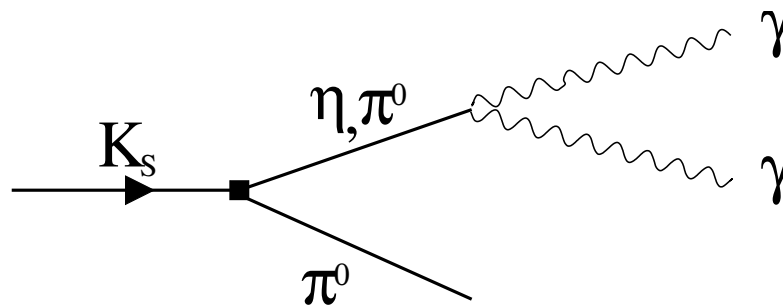

- Chiral structure of weak vertex is testable from the distribution of

$$z_q = (m_{\gamma\gamma}/m_K)^2$$

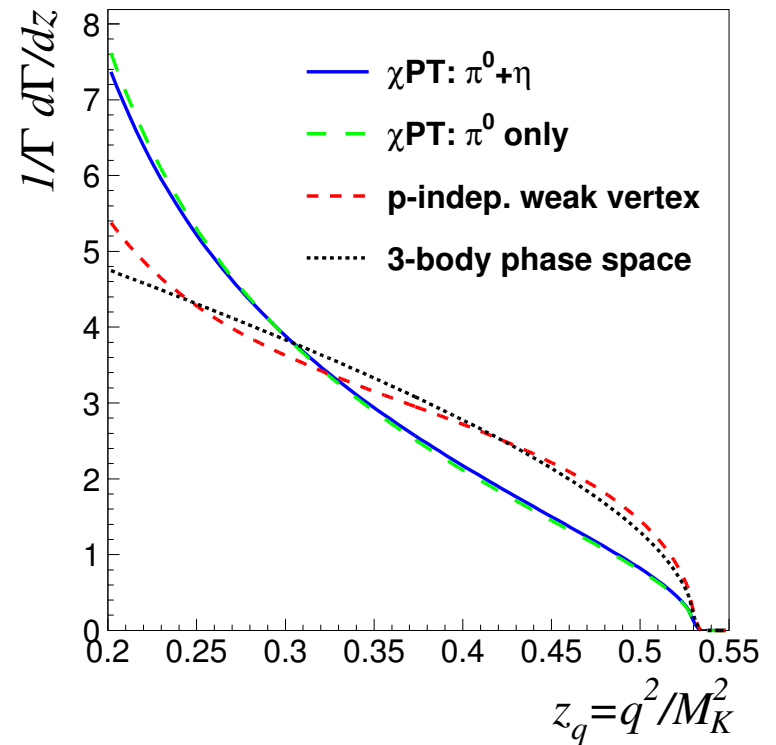

Ecker, Pitch and de Rafael: Phys. Lett B 189 (1987) 363

$$\text{BR}(K_S \rightarrow \pi^0 \gamma \gamma)_{z > 0.2} = 3.8 \times 10^{-8}$$

Data analysis: preliminary

- Data sample from 2000 near-target data
- Normalization to $K_S \rightarrow 2\pi^0$
- Main background contributions
 - $K_S \rightarrow \pi^0\pi^0$, $K_S \rightarrow \pi^0\pi_D^0$: rejected by kinematic cuts
 - $K_L \rightarrow \pi^0\gamma\gamma$: irreducible
 - $\Xi^0 \rightarrow \Lambda\pi^0 \rightarrow n\pi^0\pi^0$
 - E_γ asymmetries cuts
 - Estimated using neutron shower profile distribution
 - Beam activity: rejected by time cuts + anticounters

Signal & Background

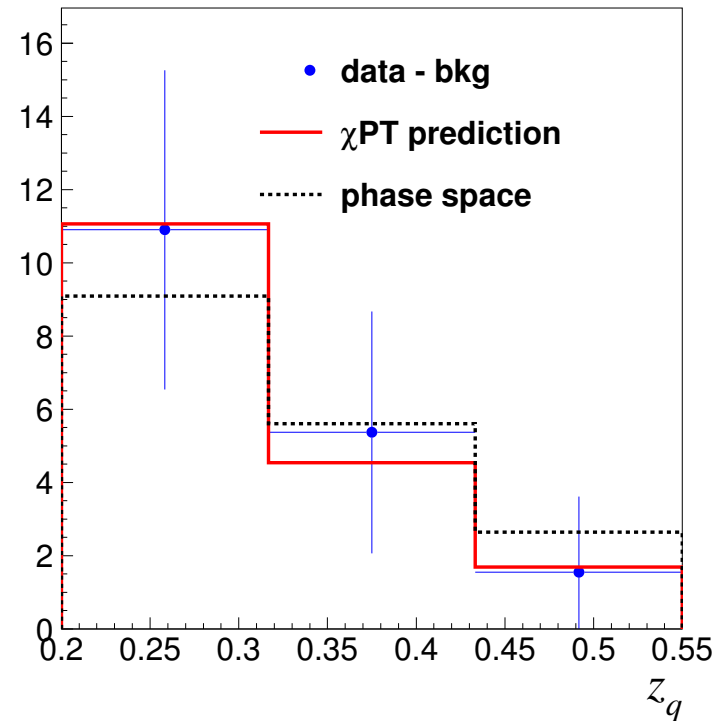
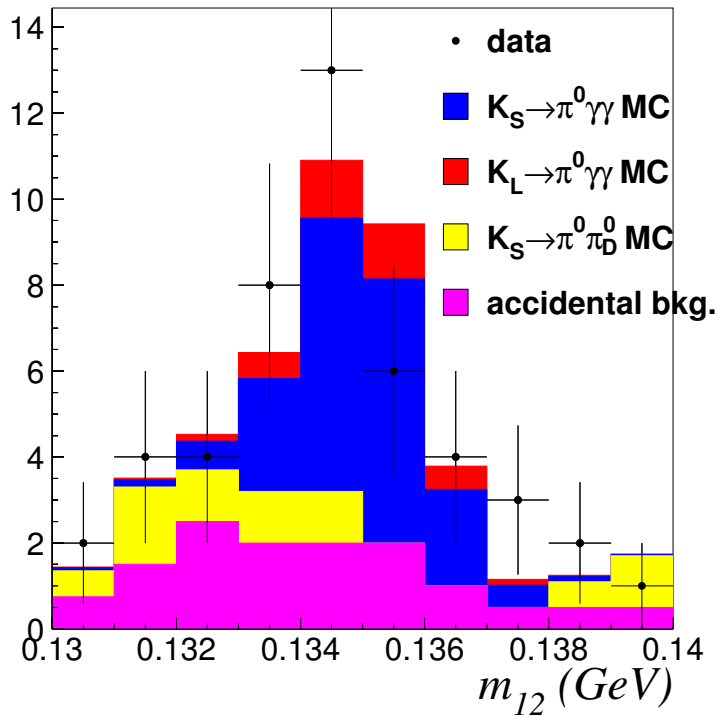

Preliminary result

$$\text{BR}(K_S \rightarrow \pi^0 \gamma \gamma)_{z > 0.2} = (4.9 \pm 1.6_{\text{stat}} \pm 0.8_{\text{syst}}) \times 10^{-8}$$

Not enough statistics to test the chiral structure of the weak vertex.

Summary

- Two tests of the χPT performed by the analysis of the data collected by the NA48 experiment have been presented.
- The results show that
 - The $K_S \rightarrow \gamma\gamma$ can be described only invoking the $\mathcal{O}(p^6)$ terms of the theory
 - More statistics is needed to prove the chiral structure of the weak vertex in the $K_S \rightarrow \pi^0\gamma\gamma$